

ARROW
GROUP

Manufacture Requirements

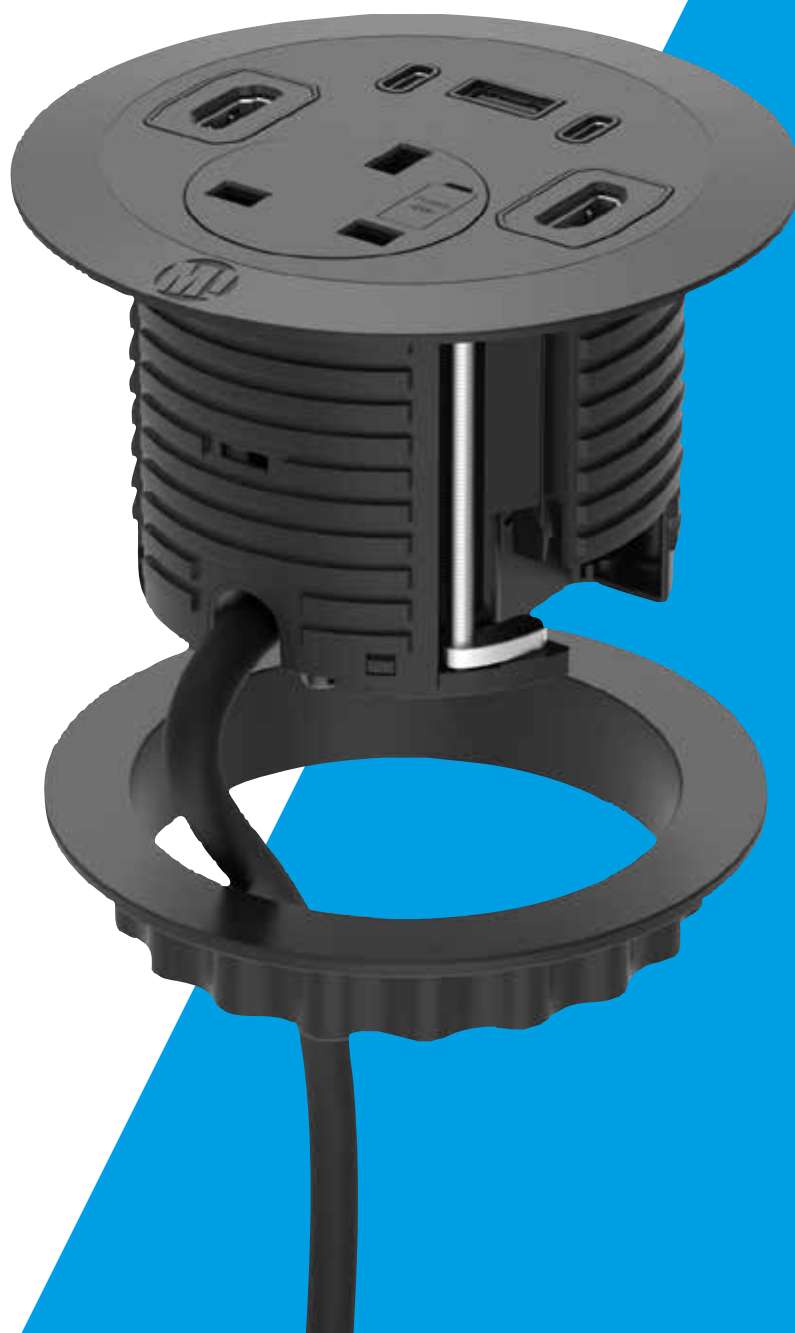

What we need from our suppliers

We are looking for factories that can provide any (or all!) of the following processes.

Mould/Tooling/Jig Production

Processes:

- Design
- FMEA
- CNC machining
- Assembly
- Ongoing maintenance

Plastic Injection Moulding

Processes:

- Moulding of ABS, Nylon, TP
- Overmoulding
- Printing (tampo/pad)
- Etching/markings

Aluminium Extrusion

Processes:

- Extrusion
- Bending
- Drilling
- Threading
- Welding
- Powder coating
- Anodising
- Chrome plating

Aluminium High Pressure Die Casting

Processes:

- Die casting
- Machining
- Threading
- Powder coating
- Anodising
- Chrome plating

Metal Fabrication

Processes:

- Fibre Laser CNC (sheet and/or tube)
- Punching
- Stamping
- Press braking
- Flow drilling
- Linishing
- TIG/MIG/spot/robotic welding
- Powder coating

Materials:

- Mild steel (>90%)
- Stainless steel (<5%)
- Spring steel (<5%)
- Aluminium (<5%)

Wood Based Panel Processing

Processes:

- Cutting
- CNC Milling
- CNC Drilling
- Straight and curved edgebanding

Materials:

- MFC (>90%)
- HPL (<5%)
- MDF (<5%)

Electronic Power and Data Assembly

Processes:

- Soldering
- Testing
- Certification

Other Products

- Gas lifts
- USB charging components
- Off the shelf fixings/washers
- Hex keys
- Custom fixings/washers
- Adhesive backed sheet materials

Assembly

Requirements:

- Ability to setup and run manual and/or semi-automated assembly lines.
- Flexibility to adapt to changing demand.
- Skilled workers with appropriate training.

Packaging

Wherever possible, materials must be:

- Biodegradable
- Recyclable
- Reusable

Whilst still providing excellent protection to the product. We aim to remove non-recyclable and non-biodegradable plastic packaging by end of 2023.

It will be useful if suppliers are already experienced with sustainable packing materials and have the ability to design and produce or procure customised packaging to suit each product

Package sizes should be as small as possible, due to both the reduced environmental impact and the reduced cost of shipping.





Example Product - Kardo Monitor Arm

Our own design product, Kardo is considered a market leading monitor arm due to the ease of installation and adjustment, quality, and value for money. We sell more than 30,000 each year, meaning hundreds of thousands of workers use Kardo monitor arms every day.

The Kardo fixed pole monitor arm is popular worldwide due to its appealing aesthetic and easy install design features.

Key manufacture features include:

- Diecasting
- Powder Coating
- Sheet metal fabrication
- Injection moulding





How we choose our suppliers

- Good, safe working conditions for all staff and clean, tidy production facilities.
- Ability to produce orders on time, in full. Shorter lead times are an advantage.
- Honesty – we value open and clear communication.
- Suppliers may be required to sign Arrow's NDA to protect our IP.
- Suppliers have an advantage if they can offer multiple services from one source, like moulding, assembly and packaging.
- Location of manufacturing facilities – those closer to UK have an advantage.
- Tooling costs and unit costs must be competitive and as stable as possible. Advance notice must be given of price changes. Suppliers who can offer credit terms will have an advantage.
- Clear quality control systems – commitment to 100% quality from the beginning to the end of every project.
- Sustainability – suppliers should have a long term plan and be committed to minimising environmental impacts
- Suppliers who are a similar size to Arrow, with sales of 5-30 million USD, are a good fit. This means that both companies can have a big impact on each other's success. Both companies will be motivated to look after each other, if we are an important part of each other's sales/purchases. It eliminates some risks, as a very small company may become too dependent on us, and a very big company may not value our business.
- Suppliers must be able to understand and communicate in English.



ARROW GROUP

+44 (0)1502 533 433

productdevelopment@arrowgroup.com

arrowgroup.com

HEADQUARTERS

Compass House

Waveney Drive

Lowestoft

NR33 0TP

